

jetStamp graphic 970



Bedienungsanleitung
Operating Manual
Manual de instrucciones
Mode d'emploi
Manual de instruções
Istruzioni per l'uso

D

GB

E

F

P

I



A

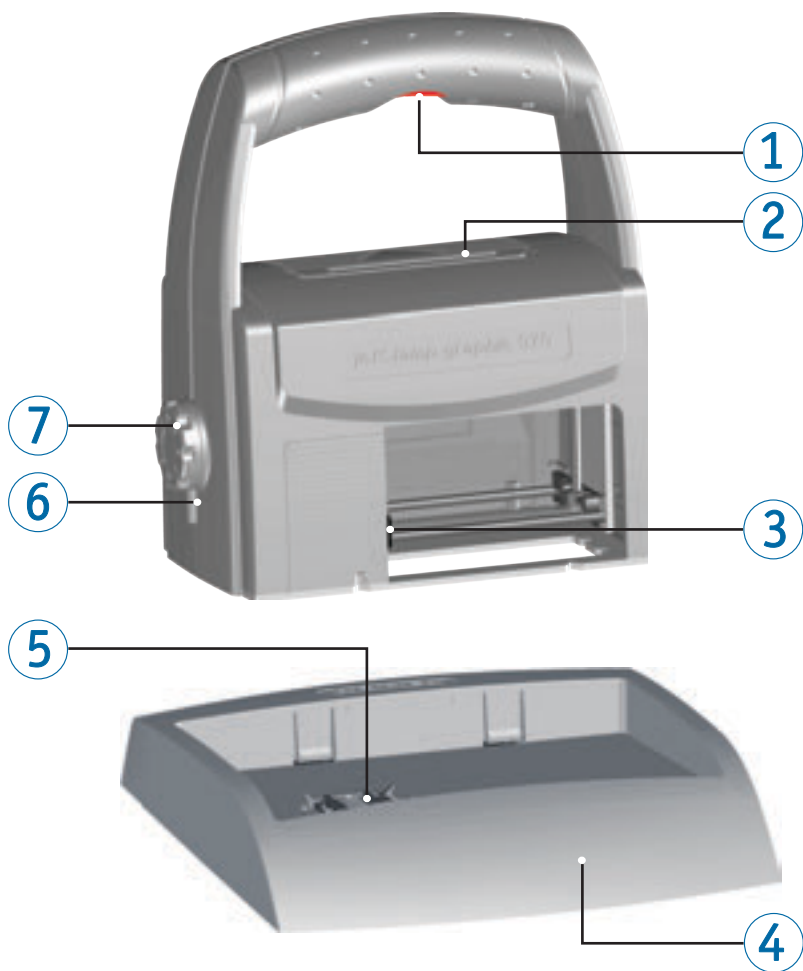

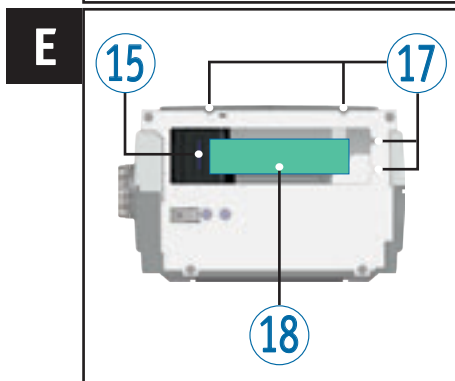
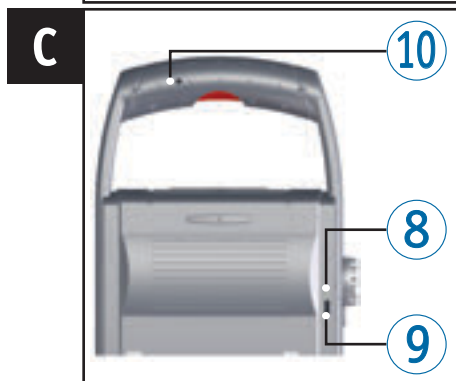
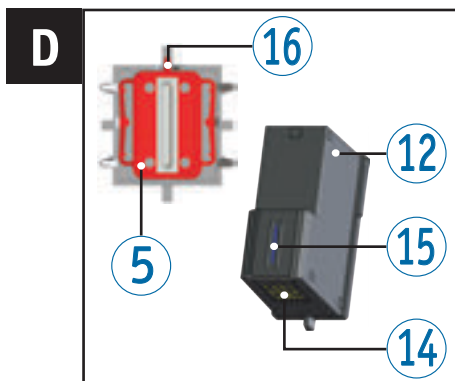
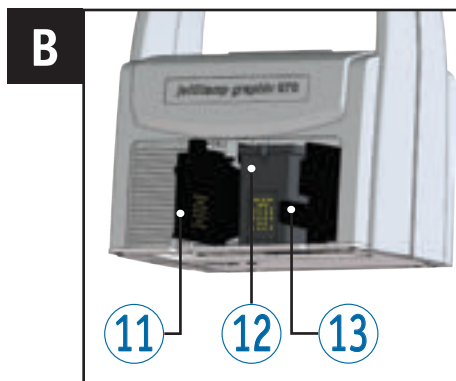



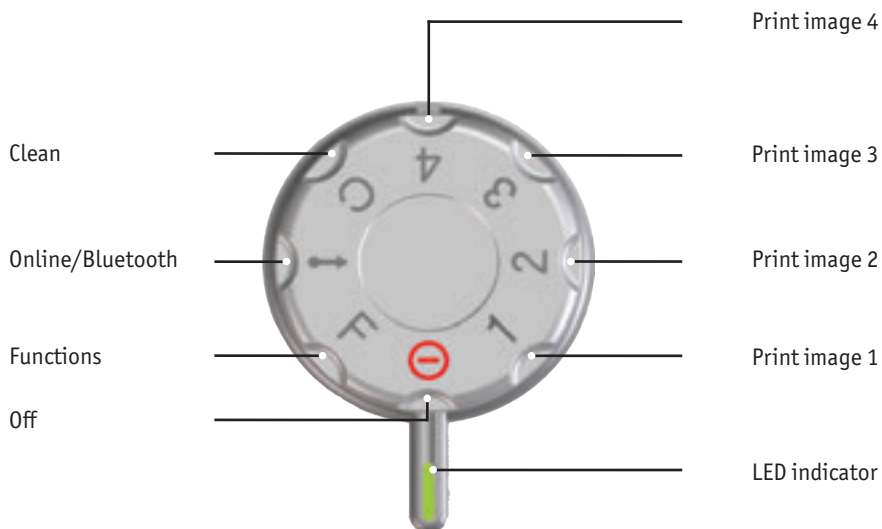

Operating Elements

- ① Trigger button
- ② Battery compartment
- ③ Print carriage
- ④ Base station
- ⑤ Protective Nozzle Seal
- ⑥ LED indicator
- ⑦ Set wheel
- ⑧ Green charge display
- ⑨ Micro-USB socket
- ⑩ Plug-in socket for external trigger
- ⑪ Folding print cartridge
- ⑫ Print cartridge
- ⑬ Lock print cartridge
- ⑭ Contact print cartridge
- ⑮ Nozzles
- ⑯ Sealing tip
- ⑰ Positioning aids
- ⑱ Print area

Set Wheel



-  The **LED indicator** marks settings.
-  On the setting **Functions**, see “Online Help”, page 57.
-  To avoid malfunctions align the settings precisely with the LED indicator!
-  To activate Bluetooth, turn the setting wheel ⑦ to position **Online/Bluetooth** (see “Bluetooth”, page 54).

Contents

jetStamp graphic 970

Operating Elements	44
Set Wheel	45

Important Notes

Rechargeable Batteries	48
------------------------------	----

Your Safety

Safety, Description	49
Safety Notes on Rechargeable Batteries	50
Safety Notes	51
Secure Handling of Print Cartridges	51

1. Preparation and Taking into Operation

1.1. Commissioning	52
1.2. Inserting Printing Cartridge	53
1.3. Test Printing	53
1.4. Bluetooth	54
1.5. Install PCset graphic Software	55
1.5.1. System Requirements	55
1.5.2. Installing Software	55
1.6. Firmware update	56

2. The Software Application PCset graphic

2.1. Prepare <i>jetStamp graphic 970</i> for PCset graphic	57
2.2. Starting the Software	57
2.3. Operating Interface	58
2.3.1. Menu Commands	59
2.3.2. Objects	60
2.3.3. Menu Bar	61
2.3.4. Additional commands	61
2.4. Example Workflow: Generate Print Pattern	62
2.4.1. Configure Print Pattern	62
2.4.2. Transfer Print Pattern to the <i>jetStamp graphic 970</i>	63
2.4.3. Print Print Pattern	63
2.5. Date/Time	64

2.5.1.	Presettings	64
2.5.2.	Context menu date/time object	66
2.6.	Numbering machine	67
2.6.1.	Presettings	67
2.6.2.	Context menu numberer object	69
2.7.	Barcode	70
2.7.1.	Presettings	70
2.7.2.	Continuous numbering/dating	72
2.7.3.	Context menu barcode object	73
2.8.	External Trigger	73
2.8.1.	Trigger via USB Interface	73
2.8.2.	Trigger via External Switch	73
3. Maintenance		
3.1.	Replace Print Cartridge	74
3.2.	Clean Print Cartridge Contacts	74
3.3.	Cleaning Nozzles	75
3.3.1.	Automatic Cleaning of Nozzles	75
3.3.2.	Manual Nozzle Cleaning	76
3.4.	Clean Protective Nozzle Seal	76
3.5.	Replace Protective Nozzle Seal	76
3.6.	Clean Housing	77
4. Recognising and Removing Interferences		
4.1.	<i>jetStamp graphic 970</i> does not work	78
4.2.	Reasons for Rechargeable Batteries Not Being Charged	78
4.3.	Visual Signals (LED)	79
4.4.	Acoustic Signals	80
5. Technical Data and Accessories		
5.1.	Rating Plate	81
5.2.	Technical Data	82
5.3.	Transport and Disposal	83
5.4.	Accessories	83
6. Contact		84
7. Index		85

Important Notes

Before commissioning of the *jetStamp graphic 970*, always read the operating instructions and in particular the safety notes with care. This prevents mistakes in handling of the marking device and connected safety risks to keep you safe and avoid damage to the device.

Rechargeable Batteries

Charging of the rechargeable batteries is electronically controlled. This warrants that the battery cells are charged in the best and protective manner.

Charging

- ▶ Charge rechargeable batteries completely before first use. Duration approx. three hours. The rechargeable batteries will not reach their full capacity yet after the first complete charge. Expect that the regular operating times are not reached.

Reaching full capacity

The full capacity is reached when the rechargeable batteries are discharged and charged again completely several times.

Your Safety

Safety, Description

⚠ DANGER

Warnings of dangers that lead to **death or severe injury directly** if not observed.

⚠ WARNING

Warnings of dangers that may lead to **death or severe injury** if not observed.

⚠ CAUTION

Warnings of dangers that may lead to **injury** if not observed.

NOTICE

Warnings of dangers that may lead to **property damage** if not observed.

- ▶ You are asked to perform actions here.



Notes and advice to make handling your *jetStamp graphic 970* even easier.



Notes on instruction videos.

Safety Notes on Rechargeable Batteries

Rechargeable batteries are subject to wear. A longer service life than six months cannot be warranted.

WARNING

Danger of explosion at contact with fire.

- ▶ Never throw rechargeable batteries into fire.

CAUTION

Danger of injury from destruction of the battery jacket when using unsuitable rechargeable batteries or non-rechargeable batteries.

- ▶ Use only rechargeable batteries intended for the device!

Type use

Only use the enclosed plug-in mains adapter or a PC USB connection to charge the batteries.

Only use rechargeable batteries (three each) of the nickel-metal-hydride type (REINER item number: 946 192 - 000), build AA.

Always replace all rechargeable batteries at once.

Non-approved rechargeable batteries may cause damage or functional impairment.

- ▶ Only use prescribed rechargeable batteries.

Insertion

Observe the polarity of the rechargeable batteries when inserting it, see icons!

Disposal



Richtlinie 2006/66/EC:

Consumers are obliged to return flat batteries and rechargeable batteries to a suitable collection site.

Batteries and rechargeable batteries can be returned free of charge to the intended community collection points or the point of sale.

The adjacent symbol means:

Do not dispose of batteries or rechargeable batteries with conventional household waste.

The following symbols may be located below the sign:

Cd = Contains more than 0.002 percent by weight cadmium

Hg = Contains more than 0.005 percent by weight mercury

Pb = Contains more than 0.004 percent by weight lead.

Safety Notes

⚠ WARNING

Danger of blinding in case of contact between ink and eyes.

- ▶ Never hold the *jetStamp graphic 970* with its nozzles pointing at the face of persons!

⚠ CAUTION

Danger of tripping and damage to the device from device lines placed freely in the room.

- ▶ Place the device lines so that they do not pose any danger source!

NOTICE

This product version is a class A device. This device can cause radio interferences in the living area. In this case, the operator may be required to take approximate measures.

NOTICE

Damage to the device due to improper transport.

- ▶ Only use packaging that provides protection from impact and shock to the device!

NOTICE

Damage to the device by moisture.

- ▶ Before commissioning, wait until the device has reached room temperature and is completely dry!

Secure Handling of Print Cartridges

⚠ WARNING

Damage to health from swallowing the ink.

- ▶ Do not swallow!
- ▶ Keep the print cartridge away from children!

1. Preparation and Taking into Operation



Find a clip on our homepage at www.reiner.de or youtube.

1.1. Commissioning



The rechargeable batteries must be charged completely before the first use. The charging time is approx. 3 hours. The rechargeable batteries are charged when the green charge display ⑧ goes out.

Inserting rechargeable batteries ⇒ Fig. A

Always replace all rechargeable batteries at once. Date, time and counter reading of the numbering machine are retained when the rechargeable batteries are removed.

- ▶ Open battery compartment ②.
- ▶ Place the textile ribbon flat across the compartment.
- ▶ Ensure correct polarity and insert the rechargeable batteries.
- ▶ Close battery compartment ②.



The textile ribbon serves simpler removal of the rechargeable batteries.

Charge batteries ⇒ Fig. C



Only connect the device to the PC when the PCset graphic-Software was installed (see "Install PCset graphic Software", page 54).



Charging at a USB hub without dedicated power supply is not possible.

- ▶ Connect the Micro-USB socket of the device ⑨ to the mains unit with the USB cable and connect the mains unit to the mains.

1.2. Inserting Printing Cartridge

Inserting printing cartridge ⇒ Fig. **A + B + D**

 Depending on ink type used, different Protective Nozzle Seals are required (see "Replace Protective Nozzle Seal", page 76).

- ▶ Put the *jetStamp graphic 970* in the base station ④.
- ▶ Turn the setting wheel ⑦ to position 1.
- ▶ Keep the trigger button ① pushed and take the device from the base station ④. Print carriage ③ moves to the middle position.
- ▶ Gently push the lock of print cartridge ⑬ to the right, until the print cartridge flap ⑪ can be opened.
- ▶ Open print cartridge flap ⑪.
- ▶ Take new print cartridge ⑫ from the packaging and remove protective film from the nozzles ⑮.
- ▶ Put the *jetStamp graphic 970* on a fixed flat surface.
- ▶ Insert printing cartridge ⑫.
- ▶ Close the print cartridge flap ⑪.
- ▶ Push the trigger button ①. Print carriage ③ moves to the home position.

1.3. Test Printing

 The *jetStamp graphic 970* is delivered with 4 factory-pre-set example print patterns.

WARNING

Danger of blinding in case of contact between ink and eyes.

- ▶ Never hold the *jetStamp graphic 970* with its nozzles ⑮ pointing at the face of persons!

Test printing ⇒ Fig. **A + C**

- ▶ Turn the setting wheel ⑦ to position 1.
- ▶ Put the device on a level surface to be printed on.
- ▶ Press the trigger button ①. Example print pattern 1 is printed.

1.4. Bluetooth

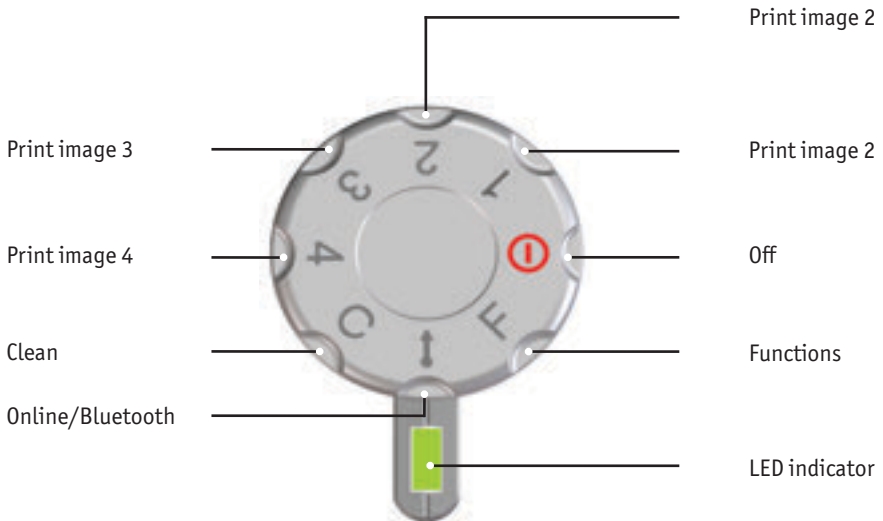

i Bluetooth cannot be activated while an a USB connection is active. With an active Bluetooth connection, a USB connection cannot be established either.

- ▶ To activate Bluetooth at the device, the setting wheel ⑦ must be turned to position **Online/Bluetooth**.

A *jetStamp graphic 970* with the serial number 123 then becomes visible under the name 970-000123 for other Bluetooth devices.

To establish a connection, the factory password "0000" is needed.

i If Bluetooth is active, the battery runtime reduces since Bluetooth is active in standby mode as well.

1.5. Install PCset graphic Software

1.5.1. System Requirements

Supported REINER devices:

- *jetStamp graphic 970*
- REINER 940

Hardware:

- PC with Pentium processor (also compatible) or higher
- Graphics adapter with a min. resolution of 800 × 600 pixels (at least 256 colours; optimal: TrueColor, 24 Bit, 16.78 million colours)
- RAM, at least 32 MB
- 10 MB free hard disc memory
- 1 free USB interface

Supported operating systems:

- Windows 2000, Windows XP, Windows XP 64 Bit
- Windows Vista, Windows Vista 64 Bit, Windows 7, Windows 7 64 Bit, Windows 8, Windows 64 Bit

1.5.2. Installing Software

Installation is only possible with administrator rights on the computer.

- ▶ Insert PCset graphic CD into the drive.
- ▶ If the installation programme does not start up automatically, start the file “**setup.exe**”.
- ▶ Observe the installation programme instructions.

1.6. Firmware update

The most up to date firmware for the *jetStamp graphic 970* can be downloaded from the REINER website (www.reiner.de).



Before performing a firmware update, transfer and save the print images on the *jetStamp graphic 970* to the PCset graphic. The print images can be damaged during the Firmware update.



Ensure that the PCset graphic is installed on your PC but **not** opened before the firmware update is started. While the firmware update is being installed, the *jetStamp graphic 970* must not be switched off.





- ▶ Connect Micro USB socket ⑨ to the PC via the USB cable.
- ▶ To activate the device, turn the setting wheel ⑦ to position 1.
- ▶ Unpack “Firmware update” and start “970 Firmware xxxx.exe”. The firmware is installed automatically. After a successful firmware update, the PCset graphic can be opened again.

2. The Software Application PCset graphic

-  The Online Help of the PCset graphic software contains further information on functions and configuration options. To open the online help, select the menu entry Help in the menu Help or push F1.

2.1. Prepare *jetStamp graphic 970* for PCset graphic

Prepare *jetStamp graphic 970* for PCset graphic ⇒ Fig. **A** + **C**

-  For the device to be correctly recognised by the computer, the PCset graphic software must be installed first.
- ▶ Connect the micro-USB socket  to the computer via the USB cable.
 - ▶ Turn the set wheel  to **1** to activate the device.
The PC recognises the *jetStamp graphic 970* as a new USB device.
The device driver software is installed automatically.
-  When the device is connected to the PC, the rechargeable batteries are charged via the USB connection.

2.2. Starting the Software

- ▶ Double-click the **REINER PCset graphic** icon .
The PCset graphic software is started.

2.3. Operating Interface

The operating interface is structured in four areas:



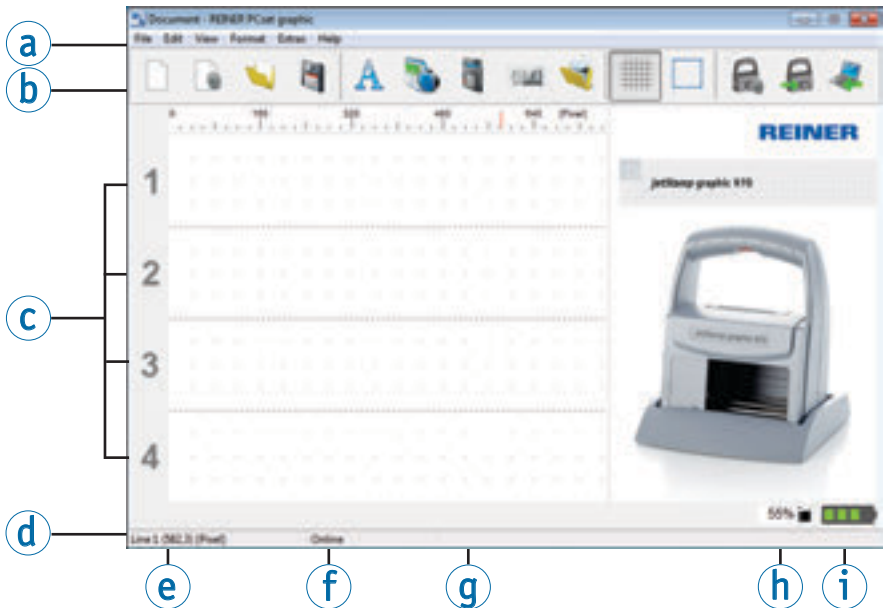







- a** Menu bar with Windows-typical and PCset graphic-specific functions
- b** Icon bar
- c** 4 lines for print pattern design
- d** Bar with different status displays



- | | |
|--------------------------|----------------------------|
| a Menu bar | f Online/Offline |
| b Icon bar | g Device messages |
| c Print patterns | h Ink level display |
| d Status displays | i Charge display |
| e Cursor position | |



2.3.1. Menu Commands







 The online help of the PCset graphic application provides further information on the icon bar, the objects and menu bar.

Icon bar 	Command	Description
	New	Resetting the display. Deleting the displayed draft.
	Settings font	Display the tab "Font" in the menu "Settings".
	Open	File selection menu to load saved print patterns.
	Save	Saving displayed print patterns as XML file.
	Grid	Activates the grid to align the objects.
	Settings	Display the tab "Print settings" in the menu "Settings".
	Transfer	The displayed print patterns are transferred to the device.
	Upload	Save the print patterns saved in the device for processing.
	Selection	For areas that were fastened via the additional function "Generate graphic". <ul style="list-style-type: none"> ▶ 1. Activate "Selection". ▶ 2. With the left mouse button pressed down, drag the selection frame over the desired area. ▶ 3. Click inside the frame with the left mouse button. The selection can now be edited like a graphic object.

2.3.2. Objects

Print patterns are assembled from objects of the five object groups described below. Objects can be freely placed by Drag & Drop (see “Example Workflow: Generate Print Pattern”, page 62).

 The format of each object group can be individually configured. Menus for format settings are called by right-clicking the respective object or in the tab “Format” in the menu bar . Detailed information (see “Online Help”, page 57).

Icon bar 	Command	Description
	Text	Enter the desired text in the cursor position. Font type and style depend on the set text format. Double-clicking the text terminates text input mode. Text can also be inserted via the Windows clipboard (see “Online Help”, page 57”). The font size is adjusted to the grid height automatically when the grid is active.
	Date/ Time	Font type, style, size and format can be set individually.
	Numbering machine	The numbering machine is used for continuous numbering. Starting value, step width and direction, font type, style and size can be set.
	Barcode	The format settings offer several barcode formats.
	Graphic	After insertion of a graphical object, a file selection window opens. Select the desired graphic and confirm with “Open”. Information on available image formats, resolutions and conversion factors; see “Online Help”, page 57”.

2.3.3. Menu Bar

In addition to the functions in the icon bar, the PCset graphic application also has a menu bar.

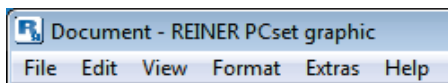

The menu bar contains both common, self-explanatory standard commands and PCset graphic-specific menu commands. The latter usually can also be called via the icons of the icon bar.

Menu command	Description (cf. menu bar ^a)
Save as	The dialogue for saving the print patterns appears.
Delete	Deletes selected objects.
Copy	Loads selected contents into the clipboard.
Insert	Inserts contents from the clipboard.
Cut	Deletes selected contents and sends them to the clipboard.
Online help	Help with detailed configuration notes and operating instructions in electronic form.
Info	Version information on the software. When the <i>jetStamp graphic 970</i> is connected, the information on model, serial number and firmware version appear here.

2.3.4. Additional commands

i Text and barcode objects can be converted to graphics. Graphics are fixed and cannot be moved. Limited editing is possible via the additional function “Selection”.

Generate graphic

- ▶ Click object with the right mouse button.
- ▶ Select “Generate graphic”.
The object is converted into a graphic.



2.4. Example Workflow: Generate Print Pattern



Entering own print patterns overwrites all 4 print patterns saved in the device. The factory pre-installed print patterns can be uploaded into the software and saved as XML files before (see “Menu Commands”, page 59).

2.4.1. Configure Print Pattern

Insert Text and Date/Time

- ▶ To generate a text object, pull the **text icon**  in line 1 (print pattern 1) with the mouse and release it in the desired position.
- ▶ Enter the desired text in the text field.
- ▶ Doubleclick the text field to place the text object.
- ▶ To generate a date/time object, pull the **date/time icon**  into line 1 (print pattern 1) with the left mouse button.
- ▶ Release it in the desired position.

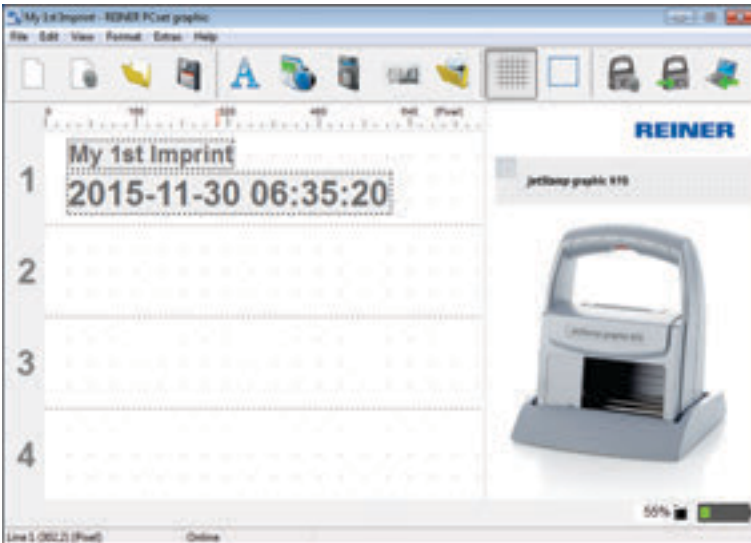

2.4.2. Transfer Print Pattern to the *jetStamp graphic 970*

- ▶ Click the **icon transfer** .
- ▶ Confirm the following dialogue window with **Yes**.

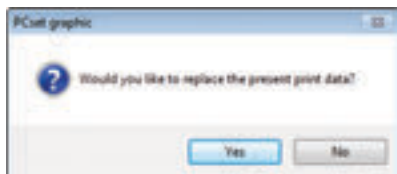

The following message will appear after a few seconds if the transfer is successful.

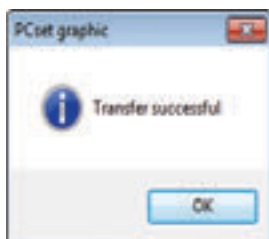

- ▶ Confirm message with **OK**.
The print pattern is saved in the *jetStamp graphic 970* now and can be printed.



2.4.3. Print Print Pattern

WARNING

Danger of blinding in case of contact between ink and eyes.

- ▶ Never hold the *jetStamp graphic 970* with its nozzles  pointing at the face of persons!

Print print pattern ⇒ **Fig. A + C**

- ▶ Turn the setting wheel  to position **1**.
 - ▶ Put the device on a level surface to be printed on.
 - ▶ Push the trigger button .
- Example print pattern 1 is printed.

2.5. Date/Time

i Up to five date/time objects can be placed (see “Objects”, page 60).

Figure style, font style, font size (see “Figure style”, page 65) and format can be set.

The date/clock time format can be globally preset.

Additionally, deviating settings can be performed for every single date/clock time object (see “Context menu date/time object”, page 66).

2.5.1. Presettings

Changed presettings apply to all future date/time objects.

- ▶ Select the tab format and click “Date/Time” in the menu bar **a**.
The configuration window for date and clock time appears.

The tab “Date and time” is structured in two areas:

- Format for date and clock time
- Figure style

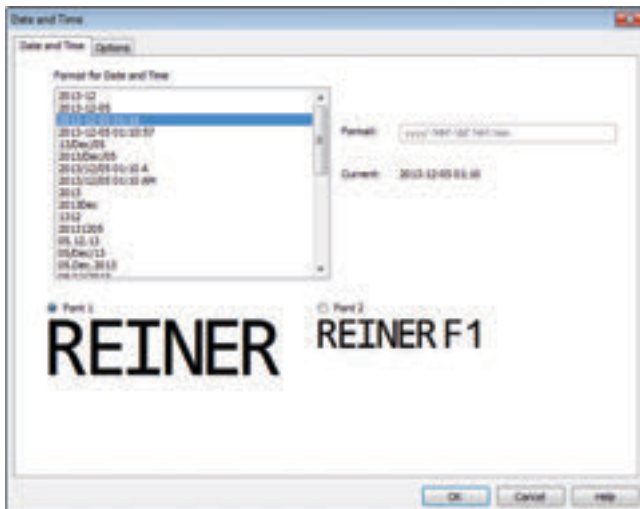

2.5.1.1. Tab date and time

Format for date and time	List of preconfigured formats. Selection by clicking.
Format	Shows the selected format in the draft view. The format can be manually configured. One abbreviation of a category each from the following table "Format abbreviations" can be used once each. Additional characters (also spaces) are inserted by being included in simple apostrophes ('). For verification purposes, whether or not the entered format is "OK" is displayed above the input field.
Current	Shows the current format in the current date.

Format abbreviation	
dd	Day of the month with two graphics (01 to 31)
MM	Day of the month with two graphics (01 to 12)
MMM	Abbreviation of the month (up to 4 characters)
yy	The last two graphics of the year (00 to 99)
yyyy	The complete year (0000 to 9999)
HH	Hour with two graphics (00 to 23)
hh	Hour with two graphics (00 to 12)
mm	Minutes with two graphics (00 to 59)
ss	Seconds with two graphics (00 to 59)
tt	Two characters for twelve-hours format with the letters AM or PM

2.5.1.2. Figure style

Selection option between "Figure style1" and "Figure style 2".

"Figure style 1" and "Figure style 2" can be configured in the tab "Figure style" in the menu "Settings" (see "Menu commands", page 59).

2.5.1.3. Tab options

An offset for date and time takes is configured in the tab "Options".

The offset can be used to, e.g., have best-before dates calculated automatically.



- ▶ Click into the respective text field.
- ▶ Enter or select offset.
- ▶ Confirm with **OK**.
The set values are added to the current system date.
The result appears in the configuration view of the imprints .

2.5.2. Context menu date/time object

If a date/time object is inserted (see "Objects", page 60), the configuration corresponds to the presettings (see "Presettings", page 64).

The context menu can be used to individually set each date/clock time object deviating from this.

- ▶ To open the context menu, right-click the desired date/time object.
The context menu opens as in the following figure.



Date/time format	Opens the configuration window for date and clock time (see "Presettings", page 64) for the selected date/time object.
Delete object	Deletes the object.

2.6. Numbering machine

The numberer is used for consecutive numbering.

 Up to five numbering machine objects can be placed (see “Objects”, page 60).

Starting value, repetitions, step width and direction, as well as figure style, font style and font size (see “Figure style”, page 68) can be set.

The numbering machine format can be globally preset.

Additionally, deviating settings can be performed for every single numberer object (see “Context menu numbering machine object”, page 69).

2.6.1. Presettings

Changed presettings apply to all future numberer objects.

- ▶ Select the tab format and click “Numbering machine” in the menu bar . The configuration window for numberers appears.

The configuration window for numberers is structured in three areas:

- Numbering machine range
- Number circle
- Figure style

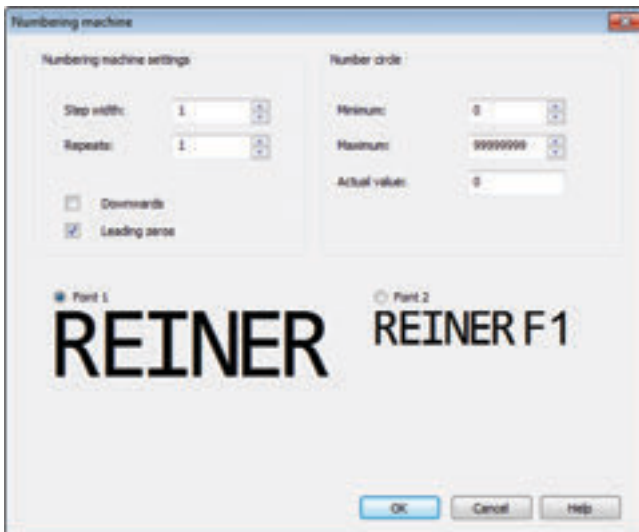

2.6.1.1. Numbering machine range

Step width	Indicates the interval at which the numberer counts on (e.g. 1,4,7... in steps of 3).
Repeats	Indicates the number of repetitions of an imprint. If, e.g., the value 3 is set, the numberer remains on the same number for three imprints before it counts on. The repeat factor can be set from 0 to 99. The numberer switches on at the value 0.
Downwards	The numberer can count up (e.g. 10, 11, 12 ...) or down (e.g. 10, 9, 8, ...).
Leading zeroes	Leading zeroes can be suppressed or printed (e.g. 5 or 00000005). The number of printed digits depends on the maximums set under "Number circle".

2.6.1.2. Number circle

The number circle defines the value range in which a numberer counter.

When the maximum or minimum value is reached (when the numberer counts up or down), the count is continued on the respective other end of the scale.

Minimum	This value marks the lower limit of the number circle.
Maximum	This value marks the upper limit of the number circle.
Actual value	The current counter reading can be set within the defined value range.

2.6.1.3. Figure style

Selection option between "Figure style 1" and "Figure style 2".

"Figure style 1" and "Figure style 2" can be configured in the tab "Figure style" in the menu "Settings" (see "Menu commands", page 59).

2.6.2. Context menu numberer object

If a numberer object is inserted (see “Objects”, page 60), the configuration corresponds to the presettings (see “Presettings”, page 67).

The context menu can be used to individually set each numberer object deviating from this.

- ▶ To open the context menu, right-click the desired numberer object.
The context menu opens.



Numbering machine	The number of the selected numberer object (1-5) is displayed.
Link to number circle	Each numberer (1-5) is first linked to a separate number circle (1-5). If several numberer objects are placed, the numberer selected can be linked to the number circle of another numberer. The dedicated number circle is rendered inactive by this. The link is used to synchronise the counter reading of different numberers. Each printing system of a linked numberer updates the counter reading of the shared number circle.
Numbering machine format	Opens the configuration window for numberer (see “Presettings”, page 67) for the selected numberer. The numberer range (see “Numberer range”, page 68) can also be set deviating from each other for numberers that are linked to a shared number circle. Settings for the number circle can only be made here when the selected numberer is linked to the dedicated number circle.
Delete object	Deletes the object.

2.7. Barcode

The PCset graphic can be used to generate different barcode formats.

Detailed information (see "Online Help", page 57).

Barcode type, character sequence, parameters and barcode size can be set.

The barcode object format can be globally preset.

2.7.1. Presettings

Global presettings can be set in the menu bar  via the tab Format "Barcode".

- OR -

Settings of already-inserted barcode objects can be called via the right mouse button "Barcode Format".

The configuration window for barcode appears.

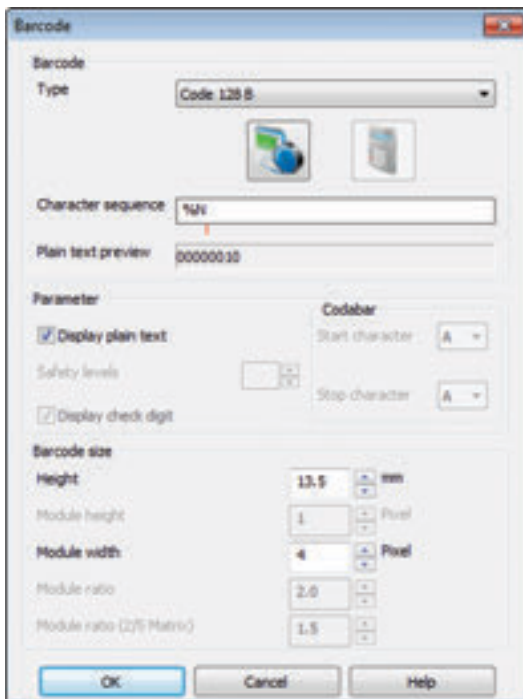

The barcode window is structured in 3 areas:







Barcode	
Type	Select the barcode type from the dropdown list.
Character sequence	Enter your desired character sequence.
Plain text preview	Indicates the character sequence without control characters.

Parameter	
Display plain text	Inserts plain text below the barcode. The plain text is the character sequence that you have entered into the barcode object.
Display check digit	Indicates the check figure additionally in plain text. To be able to use this option, you need to activate display plain text. The check figure is the last digit or position of the barcode information.
Start and stop characters:	Start and stop characters from A-D for the barcode coda bar.

Barcode size	
Height (mm)	Barcode height. Can be set from 3.5 mm - 13.5 mm.
Module height	Height of the narrowest element in pixels (stroke or gap). Only for 2D barcodes.
Module width (pixels)	Width of the narrowest element in pixels (stroke or gap).
Module ratio X:1	Ratio of wide to narrow element in calculation of the code length.
Module ratio (2/5 matrix)	Start and stop characters for the barcode type coda bar. May contain letters A-D.

2.7.2. Continuous numbering/dating

The PCset graphic differs between **fixed** and **variable** barcodes. Fixed barcodes do not change their content during printing. Variable barcodes are made up of the text as well as the date/time and/or numberer, which change during printing.

-  All in all, the variable barcode objects are limited to four. Fixed barcode objects can be inserted in any number.
 -  The variable barcodes include the barcode types “2/5 Interleaved”, “Code 39” and “Code 128 B”.
 -  Only **one** numberer and/or **one** date/time can be inserted in each barcode.
 -  At first insertion of a numberer or a date/time object, the presettings of the respective objects are loaded.
- ▶ To generate a barcode object, left-click the **barcode icon**  and pull it into a line to the desired position.
 - ▶ Push right mouse button, select context menu “Barcode Format”.
The configuration window for barcode appears.
 - ▶ To insert the **numberer**, pull it into the character sequence by Drag & Drop.
The line “Character sequence” shows %N for numberer.
 - ▶ To make the settings for the numberer, right-click %N or numberer.
The context menu opens (see “Numberer”, page 67).
Make the desired settings and confirm with **OK**.
 - ▶ To insert the **date/time**, pull it into the character sequence by Drag & Drop.
The line “Character sequence” shows %D for date/time.
 - ▶ To make the settings for the date/time, right-click %D or date/time.
The context menu opens (see “Date/time”, page 64).
Make the desired settings and confirm with **OK**.
 - ▶ To save the settings made, click **OK**.
-  The red dash below the editing field determines the inserted position of the date/time and numberer object.

2.7.3. Context menu barcode object

If a barcode object is inserted (see "Objects", page 60), the configuration corresponds to the presettings.

The context menu can be used to individually set each barcode object deviating from this.

- ▶ To open the context menu, right-click the desired barcode object.
The context menu opens as in the following figure.



Barcode format	To change the barcode format.
Generate Graphic	Fastens the barcode in the current position. Note: the barcode cannot be processed anymore after fastening.
Delete object	Deletes the object.

2.8. External Trigger

i REINER optional accessories are available for external trigger types. See online help for technical data.

2.8.1. Trigger via USB Interface

- ▶ Connect REINER USB trigger cables to Micro-USB socket **9**.
- ▶ Set set wheel **7** to the desired print pattern.
- ▶ Close contact.
Desired print pattern is printed.

2.8.2. Trigger via External Switch

Triggering via external switch uses a galvanically insulated contact.

An external voltage source is required for triggering - DC 2,4 - 24 V.

- ▶ Connect the REINER trigger cable to the plug-in socket for external triggering **10**.
- ▶ Set set wheel **7** to the desired print pattern.
- ▶ Close contact.
The desired print pattern is printed.

3. Maintenance

3.1. Replace Print Cartridge

The ink level of the print cartridge can be determined in the status display of the PCSet graphic software [d](#).

Replace print cartridge ⇒ Fig. **A + B + D**

i Depending on ink type used, different Protective Nozzle Seals are required (see “Replace Protective Nozzle Seal”, page 76).

- ▶ Put the *jetStamp graphic 970* in the base station [4](#).
- ▶ Turn the setting wheel [7](#) to position **1**.
- ▶ Keep the trigger button [1](#) pushed and take the device from the base station [4](#). Print carriage [3](#) moves to the middle position.
- ▶ Slightly push the lock of print cartridge [13](#) to the right, until the print cartridge flap [11](#) can be opened.
- ▶ Open print cartridge flap [11](#).
- ▶ Remove print cartridge [12](#) from the device.
- ▶ Take new print cartridge [12](#) from the packaging and remove protective film from the nozzles [15](#).
- ▶ Put the *jetStamp graphic 970* on a fixed flat surface.
- ▶ Inserting printing cartridge [12](#).
- ▶ Closing the print cartridge flap [11](#).
- ▶ Push the trigger button [1](#). Print carriage [3](#) moves to the home position.

3.2. Clean Print Cartridge Contacts

Clean print cartridge contacts ⇒ Fig. **A + B + D**

In rare case, contamination of the print cartridge contacts [14](#) may cause defective print results.

- ▶ Put the *jetStamp graphic 970* in the base station [4](#).
- ▶ Turn the setting wheel [7](#) to position **1**.
- ▶ Keep the trigger button [1](#) pushed and take the device from the base station [4](#). Print carriage [3](#) moves to the middle position.
- ▶ Gently push the lock of print cartridge [13](#) to the right, until the print cartridge flap [11](#) can be opened.
- ▶ Open print cartridge flap [11](#).

- ▶ Remove the print cartridge ⑫.
- ▶ Clean the print cartridge contacts ⑭ at the print cartridge ⑫ and the print cartridge flap ⑪ with a soft cloth possibly moistened slightly with ethanol (spirit).
- ▶ Put down device on a fixed underground.
- ▶ Insert printing cartridge ⑫.
- ▶ Close the print cartridge flap ⑪.
- ▶ Push the trigger button ①.
Print carriage ③ moves to the home position.

3.3. Cleaning Nozzles

If stripes are printed or if there are any problems with print quality, there may be dry ink at the nozzles ⑮.

Print without stripes:



Print with stripes:



3.3.1. Automatic Cleaning of Nozzles

⚠ WARNING

Danger of blinding in case of contact between ink and eyes.

- ▶ Never hold the *jetStamp graphic 970* with its nozzles ⑮ pointing at the face of persons!

Trigger automatic cleaning mechanism ⇒ Fig. **A + D**



A small amount of ink is ejected for cleaning of the nozzles ⑮.

- ▶ Take the device from the base station and put it on a level surface.
- ▶ Turn the setting wheel ⑦ to position **C**.
- ▶ Push the trigger button ①.

3.3.2. Manual Nozzle Cleaning

Manual nozzle cleaning ⇒ Fig. **D + E**

When the automatic nozzle cleaning does not lead to the desired success, we recommend the following measure:

- ▶ To loosen the dried ink, gently wipe a soft cloth possibly moistened slightly with Ethanol (spirit) against the nozzles ⑮ for approx. three seconds.
- ▶ Dab off dissolved ink and wipe the nozzles ⑮ dry.

3.4. Clean Protective Nozzle Seal

Clean Protective Nozzle Seal ⇒ Fig. **A + D**

The Protective Nozzle Seal ⑤ is located in the base station ④.

- ▶ Dab the Protective Nozzle Seal ⑤ clean with a soft cloth.



Clean the Protective Nozzle Seal ⑤ at regular intervals. Replace at stronger contamination or damage.

3.5. Replace Protective Nozzle Seal



Find a clip on our homepage at www.reiner.de or youtube.

Replace Protective Nozzle Seal ⇒ Fig. **A + D**



Depending on ink type used, different Protective Nozzle Seals are required.

- ▶ Push down the Protective Nozzle Seal ⑤ slightly at the front edge.
- ▶ Take it out at the Protective Nozzle Seal tip ⑯.
- ▶ Insert a new Protective Nozzle Seal into the holder.
- ▶ Slightly push down the Protective Nozzle Seal until it latches in the holder.

3.6. Clean Housing

⚠ CAUTION

Danger of electric shock when liquids enter the inside of the device.

- ▶ Pull the mains adapter from the socket.
- ▶ Inform specialist dealer or REINER service.

NOTICE

Aggressive cleaning agents may damage the housing surface.

- ▶ Do not use abrasives and plastic-dissolving detergents for cleaning.
- ▶ Clean the housing surface of the device with a soft cloth if required. Slightly moisten the cloth in water with mild detergent at stronger contamination.

4. Recognising and Removing Interferences

4.1. *jetStamp graphic 970* does not work

Troubleshooting ⇒ Fig. **A + C**

- ▶ Remove the USB cable from the *jetStamp graphic 970*.
- ▶ Open battery compartment **2**.
- ▶ Remove the rechargeable batteries.
- ▶ Wait for approx. 3 seconds.
- ▶ Replace the rechargeable batteries.
- ▶ Connect the micro-USB socket of the device **9** to the computer via the USB cable.
- ▶ Turn the setting wheel **7** to position **1**.
- ▶ Start the PCset graphic.
- ▶ Check charge status display **i** (see “Operating Interface“, page 58).

4.2. Reasons for Rechargeable Batteries Not Being Charged

- No rechargeable batteries inserted or rechargeable batteries inserted incorrectly.
- Contacts in the battery compartment defective.
- Temperature of rechargeable batteries above 40 degrees Celsius.
- Rechargeable batteries too old.
- Rechargeable batteries defective.
- Rechargeable batteries completely discharged (deep discharge).

Capacity and service life

The rechargeable batteries reach their full capacity after several charge/discharge cycles. With increasing age, the rechargeable batteries' operating time reduces.

Rechargeable batteries are subject to wear. A longer service life than six months cannot be warranted.

4.3. Visual Signals (LED)

i When the indicator flashes orange (warning), the status display **d** of the PCset graphic software shows a detailed device message **g** (see “Operating Interface”, page 58).

LED indicator	Condition	Cause	Removal	Notes
Green		Ready		
Green	Flashing	- Device is in standby mode	- Switch off and on again or push trigger button 1	- Power saving mode
Orange (warning)	Flashing, interval of 1	- No or defective print cartridge - Wrong print cartridge - Ink level writing error - Print cartridge not inserted correctly - Rechargeable battery empty - No rechargeable battery/defective rechargeable battery - Print carriage movement blocked	- Insert print cartridge - Insert print cartridge correctly - Charge rechargeable battery - Insert/replace rechargeable battery	- The detailed cause and removal can be determined in the status display d of the PCSet graphic software
Orange (warning)	Flashing, Interval of 2	- Print cartridge almost empty	- Check print	- Acoustic signal as well
Orange (warning)	Flashing, Interval of 3	- Print cartridge empty	- Replace print cartridge	- Acoustic signal as well
Orange (warning)	Flashing, Interval of 4	- <i>jetStamp graphic 970</i> not in the base station	- Put the <i>jetStamp graphic 970</i> in the base station	- The display appears after 30 seconds of non-use in standard ink, after 10 seconds in MP2 ink and after 6 seconds in MP3 ink - Acoustic signal as well
Orange (warning)	Flashing, Interval of 5	- Battery nearly flat/capacity low	- Charge/replace rechargeable battery	- Acoustic signal as well
Red (error)	Flashing, interval of 1	- Device error	- Disconnect device from the power supply for approx. 3 seconds (including rechargeable batteries and USB connection)	- If the error remains after activation, have the device inspected by the REINER-Support

GB

4.4. Acoustic Signals

Signal	Cause	Removal	Notes
1 sound impulse	- When the trigger button is pushed while the set wheel is in the position F (see "Online Help", page 57)		
1 sound impulse every 10 seconds	- No or defective print cartridge - Wrong print cartridge - Ink level writing error - Print cartridge not inserted correctly - Rechargeable battery empty - No rechargeable battery/defective rechargeable battery - Print carriage movement blocked	- Insert print cartridge - Insert print cartridge correctly - Charge rechargeable battery - Insert/replace rechargeable battery	- The detailed cause and removal can be determined in the status display of the PCSet graphic software 
2 sound impulses every 30 seconds	- Print cartridge almost empty		- Check print
3 sound impulse	- Print cartridge empty	- Replace print cartridge	
4 sound impulse	- <i>jetStamp graphic 970</i> not in the base station	- Put the <i>jetStamp graphic 970</i> in the base station	- The display appears after 30 seconds of non-use in standard ink, after 10 seconds in MP2 ink and after 6 seconds in MP3 ink - Visual signal as well
5 sound impulses per minute	- Battery nearly flat/capacity low	- Charge/replace rechargeable battery	

5. Technical Data and Accessories

5.1. Rating Plate

Observe the rating plate before the device is connected.

The rating plate is located on the bottom of the device.

The following information has the following meaning:

Mod. = Model

S/N = Serial Number

QC. = Quality Control

 = jetStamp graphic 970 meets the requirements of EC directive 2004/108/EC. The device bears the CE marking for this.

 = jetStamp graphic 970 is in accordance with the following standards or standardized documents
FCC 47 CFR Ch.1 Part 15 Bluetooth: FCC: R7TAMB2300.

 = Safety of Information Technology Equipment

 = jetStamp graphic 970 is produced according to the safety standards IEC/EN 60950-1.

Disposal



Directive 2006/66/EC:

Consumers are obliged to return flat batteries and rechargeable batteries to a suitable collection site.

Batteries and rechargeable batteries can be returned free of charge to the intended community collection points or the point of sale.

The adjacent symbol means:

Do not dispose of batteries or rechargeable batteries with conventional household waste.

The following symbols may be located below the sign:

Cd = Contains more than 0.002 percent by weight cadmium

Hg = Contains more than 0.005 percent by weight mercury

Pb = Contains more than 0.004 percent by weight lead



Directive 2002/96/EC (WEEE)

Old devices must not be disposed of in the common household waste but in a specified acceptance point for recycling of electrical and electronic devices.

5.2. Technical Data

Technical Data	
Dimensions standard device	140 × 160 × 85 mm (W × H × D)
Dimensions base station	155 × 140 × 30 mm (W × H × D)
Total height	175 mm
Weight standard device	approx. 520 g
Weight base station	approx. 480 g
Max. printing range	65 x 12.7 mm (W x H)
Max. printing speed	< 1 s/print
Print resolution	300 dpi
Battery capacity	at least 1000 prints
Print technology	Thermal inkjet
Barcode print	EAN 8, EAN 13, 2/5 Interleaved, 2/5 Industrial, 2/5 Matrix Code 39, Code 39 Full ASCII, Code Codabar, Code 93, Code 93 Full ASCIIr, Code 128 B, GS1 128 (EAN 128)
Barcode for continuous numbering/dating	Code 128 B, Code 39, 2/5 Interleaved
Graphics	BMP, JPG, TIFF, Gif
Ambience temperature for operation	10 °C ... +40 °C
Recommended ambience temperature for operation	16 °C ... +32 °C
Humidity for operation	8 % ... 80 % relative humidity
Recommended humidity for operation	10 % ... 70 % relative humidity
Temperature for storage	1 °C to +43 °C
Humidity for storage	5 % ... 80 % relative humidity
Temperature for transport	-20 °C to +60 °C (up to 12 hours)
Humidity for transport	10 % ... 90 % relative humidity
Data transfer	USB
Power supply	3 × AA NiMH rechargeable battery, can be charged through enclosed mains adapter. Input: 100 – 240 VAC, 50 – 60 Hz, 0.3 A output: 5 VDC 1 A
Standby time per battery charge	approx. 72 hours
Battery charge time	approx. three hours
Data retention (independent of batteries)	approx. 10 years
Print capacity per print cartridge	approx. 5,000 prints depending on ink and print mode
Protection type	IP 20, Degree of contamination 2, equipment class 3

5.3. Transport and Disposal

Transport

NOTICE

Damage to the device at improper transport.

- ▶ Only use packaging that protects the device from impact and hits!

Disposal



Directive 2006/66/EC:

Consumers are obliged to return flat batteries and rechargeable batteries to a suitable collection site.

Batteries and rechargeable batteries can be returned free of charge to the intended community collection points or the point of sale.

The adjacent symbol means:

Do not dispose of batteries or rechargeable batteries with conventional household waste.

The following symbols may be located below the sign:

Cd = Contains more than 0.002 percent by weight cadmium

Hg = Contains more than 0.005 percent by weight mercury

Pb = Contains more than 0.004 percent by weight lead



Directive 2002/96/EC WEEE:

Old devices must not be disposed of in the common household waste but in a specified acceptance point for recycling of electrical and electronic devices.

5.4. Accessories

Inkjet cartridges

- Order-N° P3-S-BK: 947 100 - 000
- Order-N° P3-S-MG: 947 100 - 002

Inkjet cartridges MP3

- Order-N° P3-MP3-BK: 947 100 - 120

6. Contact

Ernst Reiner GmbH & Co. KG

Baumannstr. 16

78120 Furtwangen/Germany

Phone: +49 7723 657-0

Fax: +49 7723 657-200

Email: reiner@reiner.de

www.reiner.de

© 2014 Ernst Reiner GmbH & Co. KG

All rights reserved. Translation, reprint and other reproduction of these operating instructions, even in parts and no matter the form, shall require our express written consent. We reserve the right to make content changes to these operating instructions without notice. These operating instructions were drawn up with care; however, we cannot assume any liability for any defects and errors or resulting consequential damage.

7. Index

A

Accessories	83
Acoustic Signals	80

B

Barcode.....	60
--------------	----

C

Charge display	58
Charge Rechargeable Batteries.....	52
Contact	84

D

Date/Time.....	60
Device Messages.....	58
Disposal	83

E

Example Workflow	62
Configure Print Pattern	62
Print.....	63
Transfer Print Pattern	63
External Trigger	73

G

Graphic	60
---------------	----

I

Ink level Display.....	58
Insert Print Head	53
Insert Rechargeable Batteries.....	52
Install Device Driver	57
Installing software	55
Install PCset graphic.....	55
Interferences	78

M

Maintenance	74
Cleaning Housing.....	77
Cleaning Nozzles.....	75
Cleaning Print Head Contacts	74
Clean Seal	76
Replace Print Head.....	74
Replace Seal	76

Menu bar	58
Menu command.....	59

O

Online Help.....	57
Operating Elements	44
Operating Interface	58
Additional Commands	
Generate Graphic	61
Selection.....	59
Objects	60
Barcode	60
Date/Time	60
Graphic.....	60
Numbering machine	60
Text.....	60

R

Replace Print Head	74
Replace Seal.....	76

S

Safety notes	49
Set Wheel	45
Status Displays	58

T

Technical Data	81
Test Print.....	53
Text Object.....	60
Transport.....	83
Troubleshooting.....	78

V

Visual Signals (LED)	79
----------------------------	----



REINER
www.reiner.de



Award for
Operational
Excellence

